

Preparation of Hydrogel Substrates with Tunable Mechanical Properties

Justin R. Tse¹ and Adam J. Engler¹

¹Department of Bioengineering, University of California, San Diego, La Jolla, California

ABSTRACT

The modulus of elasticity of the extracellular matrix (ECM), often referred to in a biological context as “stiffness,” naturally varies within the body, e.g., hard bones and soft tissue. Moreover, it has been found to have a profound effect on the behavior of anchorage-dependent cells. The fabrication of matrix substrates with a defined modulus of elasticity can be a useful technique to study the interactions of cells with their biophysical microenvironment. Matrix substrates composed of polyacrylamide hydrogels have an easily quantifiable elasticity that can be changed by adjusting the relative concentrations of its monomer, acrylamide, and cross-linker, bis-acrylamide. In this unit, we detail a protocol for the fabrication of statically compliant and radial-gradient polyacrylamide hydrogels, as well as the functionalization of these hydrogels with ECM proteins for cell culture. Included as well are suggestions to optimize this protocol to the choice of cell type or stiffness with a table of relative bis-acrylamide and acrylamide concentrations and expected elasticity after polymerization. *Curr. Protoc. Cell Biol.* 47:10.16.1-10.16.16. © 2010 by John Wiley & Sons, Inc.

Keywords: extracellular matrix • elasticity • hydrogel • gradient • polyacrylamide

INTRODUCTION

The extracellular matrix (ECM) provides both mechanical support for surrounding cells and a variety of biochemical and biophysical signals that influence cellular behavior. These are largely the result of the ECM composition that includes adhesive glycoproteins, fibrous matrix proteins, proteoglycans, and glycosaminoglycans (Badylak, 2005). These signals are coupled in the body and together they create a 3-dimensional microenvironment for cell growth (Cukierman et al., 2001). In particular, the modulus of elasticity E , or “stiffness,” is a characteristic of the ECM that certain anchorage-dependent cells can sense and respond to with a variety of cellular processes (Discher et al., 2005). E of a material represents the intrinsic resistance of organs and tissues to stress, and in its simplest mathematical form can be expressed as the tensile stress, σ , or force applied per unit area, divided by the resultant strain, ϵ , or relative change in length (Discher et al., 2005). Though highly nonlinear (Fung, 1993), at the physiologically appropriate strains, the degree of stiffness varies dramatically between tissues: brain ($E_{\text{brain}} \sim 0.1\text{--}1$ kPa) is clearly softer than striated skeletal muscle ($E_{\text{muscle}} \sim 8\text{--}17$ kPa), which is less stiff than precalcified bone ($E_{\text{precalcified bone}} = 25\text{--}40$ kPa; Engler et al., 2006). At the cellular level, such changes in substrate elasticity have been observed to influence several cellular behaviors, including cell proliferation, locomotion, adhesion, spreading, morphology, striation, and even differentiation of stem cells (Pelham and Wang, 1997; Wang et al., 2000; Flanagan et al., 2002; Engler et al., 2004b, 2006; Khatiwala et al., 2006; Reinhart-King et al., 2005; Discher et al., 2009). That said, these properties are not static within the body; they are often displayed in highly complex gradients, such as those of stiffness at tissue interfaces. In vitro, the variation of E across a substrate has been shown to elicit directly cell migration or “durotaxis” in fibroblasts and vascular smooth muscle cells (Lo et al., 2000; Wong et al., 2003), indicating again that intrinsic matrix properties can influence cell behavior. Moreover, they are coupled, meaning that both mechanics and biochemical signals can

Table 10.16.1 Expected Modulus of Elasticity after Polymerization of Relative Acrylamide and Bis-Acrylamide Concentrations^a

Acrylamide %	Bis-acrylamide%	Acrylamide from 40% stock solution (ml)	Bis-acrylamide from 2% stock solution (ml)	Water (ml)	$E \pm \text{St. Dev.}$ (kPa)
3	0.03	0.75	0.15	9.1	0.20 ± 0.03
3	0.06	0.75	0.3	8.95	0.48 ± 0.16
3	0.1	0.75	0.5	8.75	1.10 ± 0.34
3	0.15	0.75	0.75	8.5	1.37 ± 0.22
3	0.225	0.75	1.125	8.125	1.67 ± 0.14
3	0.3	0.75	1.5	7.75	1.78 ± 0.19
4	0.03	1	0.15	8.85	0.71 ± 0.24
4	0.06	1	0.3	8.7	1.16 ± 0.54
4	0.1	1	0.5	8.5	2.01 ± 0.75
4	0.15	1	0.75	8.25	2.55 ± 0.17
4	0.225	1	1.125	7.875	3.13 ± 0.42
4	0.3	1	1.5	7.5	3.24 ± 0.58
5	0.03	1.25	0.15	8.6	1.00 ± 0.31
5	0.06	1.25	0.3	8.45	1.80 ± 0.44
5	0.1	1.25	0.5	8.25	3.15 ± 0.85
5	0.15	1.25	0.75	8	4.47 ± 1.19
5	0.225	1.25	1.125	7.625	8.44 ± 0.82
5	0.3	1.25	1.5	7.25	8.73 ± 0.79
8	0.048	2	0.24	7.76	2.61 ± 0.82
8	0.264	2	1.32	6.68	19.66 ± 1.19
8	0.48	2	2.4	5.6	40.40 ± 2.39
10	0.03	2.5	0.15	7.35	2.83
10	0.06	2.5	0.3	7.2	7.43
10	0.1	2.5	0.5	7	10.61
10	0.15	2.5	0.75	6.75	16.70
10	0.225	2.5	1.125	6.375	23.43
10	0.3	2.5	1.5	6	34.88

^aThis table shows the relative concentrations of acrylamide and bis-acrylamide and their expected modulus of elasticity after polymerization in water. Acrylamide and bis-acrylamide can be kept premixed in solution for weeks to months at 4°C. At least 3 hydrogels per sample and 50 indentations per hydrogel were assessed for these measurements.

jointly influence cells, e.g., stem cells differentiate in response to an appropriately compliant material, but only when coupled to the right matrix ligand (Rowlands et al., 2008).

To study these affects [in isolation](#) and together, this unit describes the fabrication of hydrogel substrates of a defined E for the culture of cells. Basic Protocol 1 describes [procedures](#) for fabricating hydrogels of a constant E , [termed](#) statically compliant hydrogels, and of a gradient E , termed radial-gradient hydrogels, onto glass coverslips from non-biodegradable polyacrylamide. Basic Protocol 2 describes a technique to covalently coat the matrix substrate with an ECM protein, while the Support Protocol describes how to create an [apparatus](#) to make radial-gradient hydrogels. Table 10.16.1 provides expected E values after polymerization of various ratios of acrylamide and bis-acrylamide solutions.

FABRICATION OF STATICALLY COMPLIANT MATRIX SUBSTRATES OF VARYING STIFFNESS

Several different types of polymers, including both nonbiodegradable and biodegradable types, can be used to fabricate matrix substrates of varying stiffness. Here, we introduce a simple method to create matrix substrates from polyacrylamide (PA) with a tunable elasticity. Besides producing statically compliant hydrogels, this technique can be adapted to produce hydrogels with a gradient of elasticity (Alternate Protocol). PA offers several important advantages for its application as a biomaterial for cell culture. (1) The modulus of elasticity of the substrate can be varied by changing relative concentrations of acrylamide and bis-acrylamide (Pelham and Wang, 1997). (2) The surface chemistry of PA can be kept constant while changing its mechanical properties (Pelham and Wang, 1997; Khatiwala et al., 2006), a characteristic whose importance is highlighted by a study demonstrating the dependence of cell spreading on ligand density (Engler et al., 2004a). (3) PA is generally nonfouling, meaning that the adsorption of serum proteins or the nonspecific binding of cell surface receptors is typically negligible. As a result, only adhesive molecules chosen to be covalently attached to the surface of the gel can serve as ligands for cell attachment (Georges and Janmey, 2005). (4) The pore sizes of the gel are on the order of 100 nm, preventing cells (~15 μm in diameter) and their extensions, such as growth cones (~5 μm in diameter) from entering the substrate (Flanagan et al., 2002). (5) Immunofluorescence is made possible at high magnifications because of the thin, translucent quality of PA gels.

PA gels are produced in this protocol by mixing various acrylamide and bis-acrylamide concentrations and inducing free radical polymerization. A table of expected modulus of elasticity values given the input concentrations of acrylamide and bis-acrylamide is provided (Table 10.16.1), while we also include a plot in Figure 10.16.3 that presents the spatial elasticity gradient possible using the gradient gel method detailed here. PA gel modulus of elasticity was quantified using atomic force microscopy (AFM), which is a nano-indentation method of calculating elasticity. This technique has been extensively detailed elsewhere (Rotsch et al., 1999; Rotsch and Radmacher, 2000).

Materials

0.1 M NaOH

Distilled H₂O

3-Aminopropyltriethoxysilane (APES) 氨丙基三乙氧基硅烷

0.5% (v/v) glutaraldehyde in phosphate-buffered saline (PBS; Cellgro, cat. no. 46-013-CM)

Dichlorodimethylsilane (DCDMS) 二氯二甲基硅烷

40% (w/v) acrylamide stock solution (Sigma-Aldrich, cat. no. A4058) 丙烯酰胺

2% (w/v) bis-acrylamide stock solution (Sigma-Aldrich, cat. no. M1533) 双丙烯酰胺

Phosphate-buffered saline (PBS), optional

Tetramethylethylenediamine (TEMED) 四甲基乙二胺

10% (wv) ammonium persulfate (APS) 过硫酸铵

25-mm circular coverslips (for 6-well plate)

Hot plate 电热板

35-mm petri di

25 × 75-mm glass slides

Vacuum desiccator 真空干燥器

Vortex mixer 漩涡混合器

6-well plate, optional

Prepare amino-silanated coverslip(s)

1. Place 25-mm coverslip(s) on a hot plate and add 500 μl of 0.1 M NaOH to the coverslip so that the solution covers the entire glass surface.
2. Heat the coverslip with solution at $\sim 80^\circ\text{C}$ until the liquid is evaporated.

The solution should not boil, and there should be a thin semi-transparent film of NaOH remaining on the coverslip(s) after evaporation.

3. Repeat step 1 by diluting the NaOH by adding 500 μl of distilled H_2O to the coverslip and heating the solution at 80°C until the film of NaOH is uniform.

This step should be performed if and only if steps 1 and 2 resulted in a non-uniform film. A uniform film of NaOH is important for uniform gel attachment.

4. Place coverslip(s) in a nitrogen-filled tent. Add 200 μl of APES to the surface of the coverslip(s). Allow 5 min for the APES to react.

If a nitrogen tent is unavailable, this step can be done in the fume hood. 通风橱 Since APES will react with the oxygen in the air, use 250 μl of APES to compensate for the loss of reactivity. A thin film will likely result on the surface of the APES solution and additional washing cycles in step 6 may be necessary to remove it.

5. Rinse the coverslip(s) with distilled H_2O under the distilled H_2O tap水龙头 to ensure both the top and bottom of the coverslip(s) is rinsed.

It is important to completely rinse off the unreacted APES, for it will create an orange-brown precipitate with glutaraldehyde (see step 8) that fluoresces under UV light and can thus interfere with immunostaining techniques.

6. Place the coverslip(s) in distilled H_2O into a petri dish and rinse the coverslips twice, each time in ~ 10 ml (or enough to immerse the coverslip) distilled water for 5 min each. 玻片放于培养皿中, 然后纯水冲洗两次, 每次5分钟

7. Aspirate the second distilled H_2O wash solution and add ~ 10 ml (or enough to immerse the coverslip) of 0.5% glutaraldehyde in PBS. Let the solution stand for 30 min. 0.5%戊二醛浸泡30分钟

8. Aspirate the solution and dry the coverslips with a Kimwipe, by allowing the coverslips to dry naturally in air, or by blowing nitrogen on them.

The amino-silanated 氨基硅烷化 coverslips remain viable for 48 hr. However, to prepare radial-gradient hydrogels, it is best to use the amino-silanated coverslips immediately after they are created to ensure uniform gel attachment.

Prepare chloro-silanated glass slide(s)

9. Using separate glass slides, spread about 100 μl of DCDMS onto each slide in the fume hood. Ensure that the solution coats the entire surface of the slides. Allow to react for up to 5 min before removing the excess DCDMS with a Kimwipe and rinse 1 min under distilled H_2O .

Prepare statically compliant hydrogel(s)

10. Mix acrylamide and bis-acrylamide to their desired concentrations in either distilled H_2O or PBS.

See Table 10.16.1 for concentrations and corresponding elastic modulus.

The elastic moduli will be slightly lower if the solutions are made in water, due to gel swelling when placed in cell culture media. This effect can be directly measured by AFM or other mechanical techniques.

Acrylamide and bis-acrylamide can be kept together in solution for weeks to months, though the sterility of the stock solution should be closely maintained by filter sterilization.

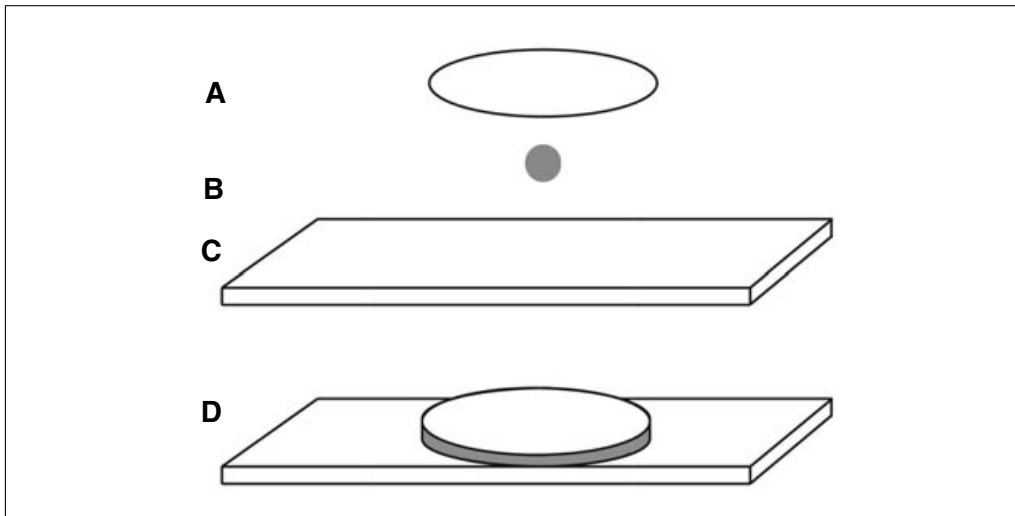

Figure 10.16.1 Exploded schematic of the setup for statically compliant PA hydrogels. The gel-glass composite includes (A) the amino-silanated coverslip, (B) polymerizing solution, and (C) chloro-silanated glass slide (C). (D) The completed setup is shown.

If not sterile, contaminants from the gel could adversely affect cell culture and induce infections.

11. Degas the mixture under strong vacuum for 15 min to exhaust the solution of dissolved oxygen.

Dissolved oxygen in the solution will act as a sink for the subsequent free radical polymerization. Degassing the solution not only speeds up polymerization but ensures more uniform polymerization as well. 自由游离基引发聚合

12. Add 1/100 total volume of APS and 1/1000 total volume of TEMED to gel solutions.
13. Vortex the polymerizing solution.
14. Quickly pipet 25 μl of the gel solution (see Fig. 10.16.1B) onto the treated side of the chloro-silanated glass slide(s) (see Fig. 10.16.1C) and add the amino-silanated coverslip(s) with the treated side down (see Fig. 10.16.1A).

See Figure 10.16.1D for how the completed glass-gel-coverslip composite should appear.

Essentially, the setup resembles a “sandwich” in which the polymerizing solution sits between the chloro-silanated glass slide and the amino-silanated coverslip.

15. Allow the gel to polymerize for 5 to 30 min. Monitor the unused solution to determine when the solution is fully polymerized.

Shorter polymerization times may result in insufficient polymerization of all available monomers and may cause the mechanical properties of the hydrogels to vary from the values noted here.

16. Remove the bottom glass slide and discard. Place the top coverslip-gel composite in a 35-mm petri dish or 6-well plate in PBS or dH_2O depending on what was used to dilute the acrylamide. Make sure that the gel-coated side faces up.
17. To remove unpolymerized acrylamide rinse twice, each time for 5 min in PBS or distilled H_2O depending on what was used to dilute the acrylamide.

These hydrogels can be stored for long periods of time without losing any of their mechanical properties. To store them, immerse the hydrogels in water or PBS to keep them hydrated and store them at 4°C.

FABRICATION OF RADIAL-GRADIENT MATRIX SUBSTRATES OF
VARYING STIFFNESS

Radial-gradient hydrogels can be fabricated by photoinitiated polymerization as this technique allows for spatial control over the mechanical properties of the material. Among the commercially available photoinitiators, 1-[4-(2-hydroxyethoxy)-phenyl]-2-hydroxy-2-methyl-1-propanone, also known as Irgacure 2959, is commonly used for gel encapsulation and other photopolymerization reactions (Fedorovich et al., 2009). However, there are several limitations to using Irgacure 2959 that affect the maximum attainable polymerization rate, including its low solubility in water and its relatively narrow excitation spectrum. Nevertheless, we found that Irgacure 2959 as a photoinitiator is sufficient in producing spatial gradients of stiffness for our hydrogels. A detailed study on the kinetic properties of Irgacure 2959 and a novel photoinitiator that can be applied for this technique can be found in Fairbanks et al. (2009).

In this polymerization system, UV light of the appropriate wavelength catalyzes the free radical polymerization of acrylamide and bis-acrylamide by cleaving the Irgacure 2959 molecules into free radicals. While the mechanism for polymerization is similar to that of the fabrication of statically compliant hydrogels, UV light and Irgacure 2959 serve as the catalyst and the free-radical donor for the reaction, respectively, instead of TEMED and APS. The photomask filters the exposure of the UV light and creates a gradient of UV light intensity, which will result in a spatial gradient of polymerization rate. Because the polymerization reaction is stopped before completion by removing the UV light source, a polymer with a gradient of cross-linking density, or elasticity, is created through this process.

While the fabrication of statically compliant PA hydrogels is relatively straightforward, there are many parameters that need to be adjusted before the gradient gel can be created. These parameters include UV intensity, wavelength, and exposure time as well as distance from the UV light source, photoinitiator concentration, gel thickness, photomask grayscale, and acrylamide and bis-acrylamide concentration. Because of variations in the UV light source and photomask, several trials by the user are necessary to optimize the protocol. **It is recommended to only vary the UV exposure time and the acrylamide and bis-acrylamide concentrations while keeping the other parameters constant.**

Materials

- 40% (w/v) acrylamide stock solution (Sigma-Aldrich, cat. no. A4058)
- 2% (w/v) bis-acrylamide stock solution (Sigma-Aldrich, cat. no. M1533)
- Distilled water or phosphate-buffered saline (PBS; Cellgro, cat. no. 46-013-CM)
- Irgacure 2959 (Ciba)
- Vacuum desiccator
- Gradient gel apparatus
- Photomask
- 254-nm UV light source
- Chloro-silane-treated 25 × 75-mm glass slides (Basic Protocol 1)
- APES-coated glass coverslips (Basic Protocol 1)
- 35-mm petri dish(es) or 6-well plates

1. Mix acrylamide and bis-acrylamide to their desired concentrations in distilled H₂O or PBS.

*See Table 10.16.1 for concentrations and corresponding elastic modulus. **The corresponding elastic modulus represents the maximum elastic modulus for the gradient gel.** In our setup, we used a concentration of 10% acrylamide and 0.3% bis-acrylamide to obtain a gradient with a range of ~1 kPa to 14 kPa. Often, the range of the gradient is limited by the diffusion of acrylamide monomers during polymerization. These concentrations can be adjusted to obtain a desired range. However, some optimization will be necessary.*

2. Add Irgacure 2959 at a concentration of 0.5% (w/v).

It is best to use this solution immediately after mixing and to remake a new solution for each batch of gels because the initiator, Irgacure 2959, reacts slowly with the acrylamide and bis-acrylamide due to incidental light exposure.

Irgacure 2959 is relatively insoluble in water; the solution can be placed in a warm water bath to speed up dissolving.

As with the statically compliant gels, sterility is important for longer-term culture. Filter sterilization of all solutions is recommended.

3. Degas the mixture under strong vacuum for 60 min to speed up polymerization.

Because the polymerization time is a function of both the amount of UV exposure and the concentration of dissolved gas in solution, it is important to remove all dissolved gases that may limit the free radical polymerization.

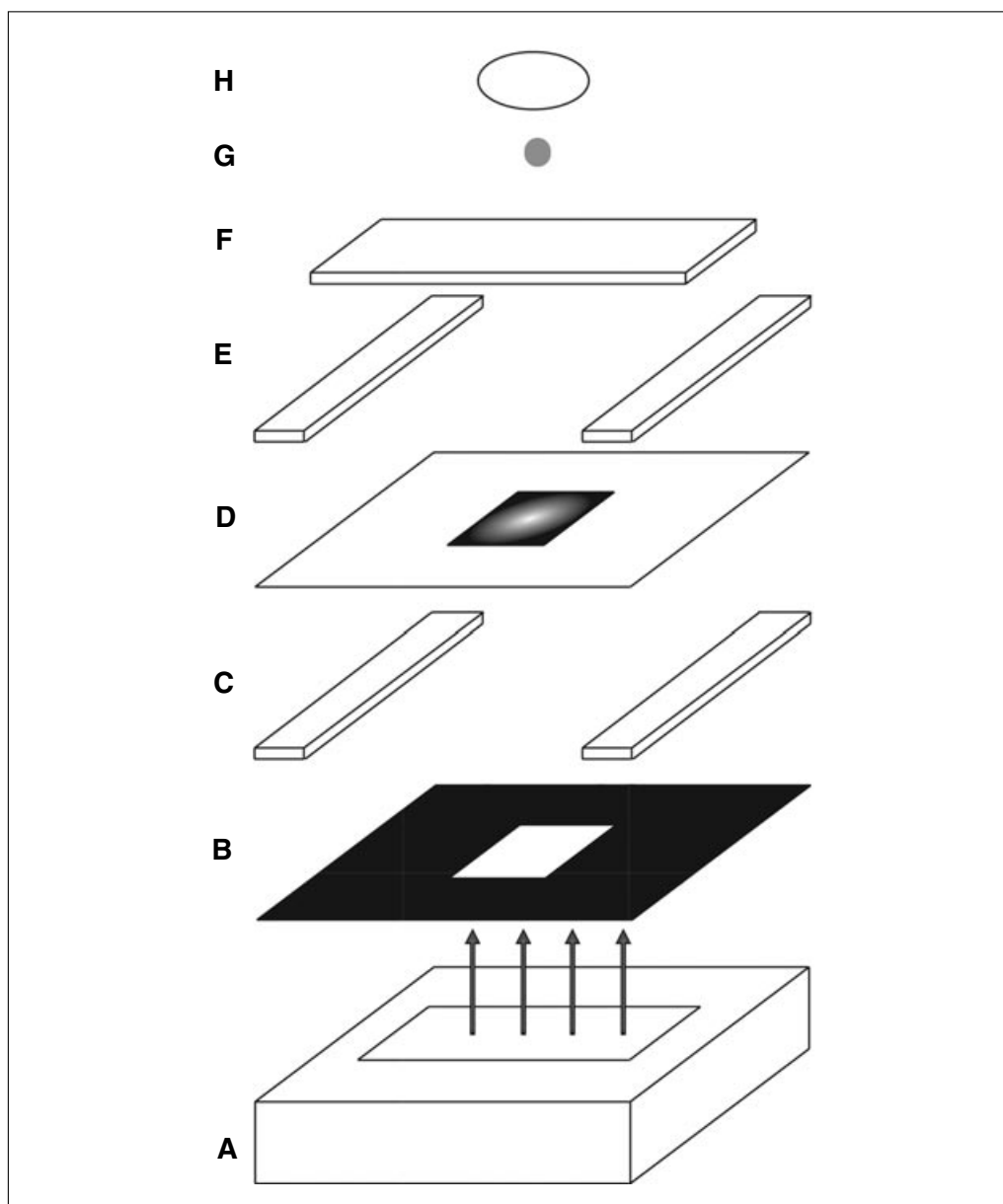

Figure 10.16.2 Exploded schematic of the setup for radial-gradient hydrogels. The setup includes (A) the UV light box, (B) negative photomask, (C & E) spacers, (D) photomask, (F) chloro-silanated glass slide, (G) polymerizing solution, and (H) amino-silanated coverslip.

- Set up in the gradient-gel apparatus (Support Protocol 1) by placing the negative photomask on the UV light box (see Fig. 10.16.2A and B), the photomask on top of the UV light box (see Fig. 10.16.2D), and the chloro-silanated glass slide on top of the photomask (see Fig. 10.16.2D). Use spacers as necessary to separate each component (see Fig. 10.16.2C and E).

The distance between the photomask and the chloro-silanated glass slide should be minimized to ensure the greatest resolution. For our setup, the distance was kept within 1 mm.

- Pipet 30 μl of the gel solution (see Fig. 10.16.2G) onto the treated side of the chloro-silanated glass slide (see Fig. 10.16.2F) as set up in the gradient-gel apparatus (Support Protocol 1) and add the amino-silanated coverslip (see Fig. 10.16.2H) with the treated side down.

To maintain the same approximate gel thickness as that of the statically compliant hydrogels, slightly more gel solution is added to compensate for the incomplete polymerization that takes place at the edge of the gels.

It is possible to make thicker gels by increasing the volume of gel solution added to the chloro-silanated glass slide. However, the thickness of the gel introduces another parameter to the gradient elasticity as thicker gels allow greater diffusion of monomers in the x-y plane during polymerization, effectively decreasing the range of stiffness.

- Turn on the UV light for the desired exposure time.

The amount of UV light exposure can be varied to produce a desired gradient range. Since UV intensity, distance, photomask quality, and other parameters differ for each setup, it is important to optimize this parameter to produce the desired range. For our setup and gradient range, we used a polymerization time of 3 min 30 sec.

Fig. 10.16.3 shows the spatially elastic gradient that can be obtained by using this technique.

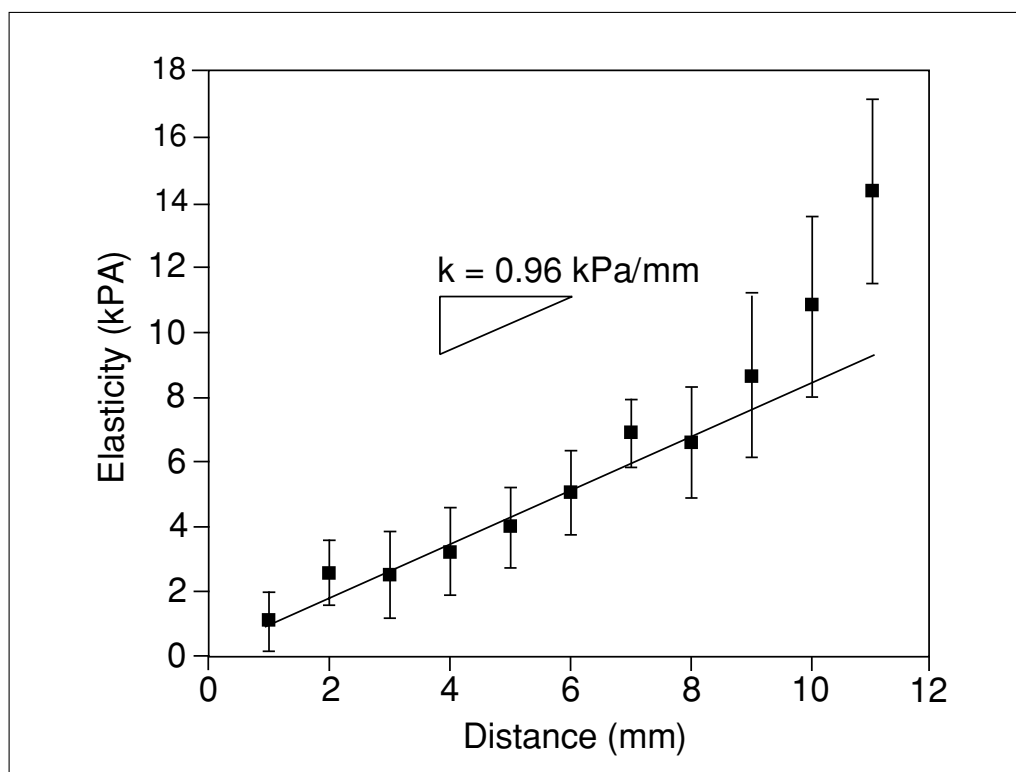

Figure 10.16.3 Spatial map of the elasticity (kPa) versus distance from the center of the gel (mm) characterized by AFM that can be obtained by fabricating the radial-gradient hydrogel detailed in the Alternate Protocol. The PA hydrogels represented in the figure were cast on coverslips of 25-mm diameter.

7. Remove the bottom glass slide and discard. Place the top coverslip-gel composite in a 35-mm petri dish or 6-well plate in PBS or distilled H₂O depending on what was used to dilute the acrylamide. Make sure that the gel-coated side faces up.
8. Rinse twice to remove unpolymerized acrylamide with 2 ml PBS or distilled H₂O depending on what was used to dilute the acrylamide.

These hydrogels can be stored for long periods of time without losing any of their mechanical properties. To store them, immerse the hydrogels in water or PBS to keep them hydrated and store them at 4°C.

PREPARATION OF MATRIX PROTEIN SUBSTRATES OF VARYING STIFFNESS FOR CELL CULTURE

BASIC PROTOCOL 2

For many synthetic materials, before cell attachment can take place, an ECM protein coating is needed to promote adhesion. However, polyacrylamide hydrogels do not readily adsorb proteins, and thus it is essential to covalently bind proteins to the gel to ensure efficient cell attachment (Pelham and Wang, 1997). In this protocol, sulfo-SANPAH, a heterobifunctional protein cross-linker, is used to covalently bind proteins to the polyacrylamide substrates. Sulfo-SANPAH contains a nitrophenylazide group that is most photoreactive at wavelengths of 320 to 350 nm toward polyacrylamide. Exposure of the gel in a solution of Sulfo-SANPAH with a UV light source at 365 or 320 nm covalently links the sulfo-SANPAH to the polyacrylamide hydrogel.

羟基丁二酰亚胺酯 The *N*-hydroxysuccinimide ester in sulfo-SANPAH can then react with the primary amines of proteins to complete the attachment of proteins to the surface of the gel. Figure 10.16.4 shows a schematic of the steps in the functionalization of the PA hydrogel.

6-((丙烯酸)氨基)己酸 Although not detailed here, an alternative conjugation method would be to incorporate 6-((丙烯酸)氨基)己酸 into the gel solution of Basic Protocol 1 as it polymerizes. Reinhart-King and coworkers have successfully employed such a technique where the hexanoic acid copolymerizes into the gel and displays an *N*-hydroxysuccinimide ester for amine-containing protein binding (Reinhart-King et al., 2008). Carbodiimide has also been employed, though details may be found elsewhere (Grabarek and Gergely, 1990).

One of the concerns with ECM protein coatings is the variability of the ligand density among the different substrates and homogeneity of the ligand coating. With regards to this protocol, data suggests that the ligand is the limiting reagent in this reaction, and thus, the surface density of the ligand can be varied by changing the concentration of the ligand (Gaudet et al., 2003). This directly affects key cellular properties, e.g. cell spreading (Engler et al, 2004a). On the other hand, the surface chemistry of the matrix stays constant while the mechanical properties of the substrate are varied. Pelham and Wang (1997) report that the relative surface concentration of collagen varied <3% among the substrates, regardless of the modulus of elasticity, and several other studies confirm this observation (Wang et al., 2000; Khatiwala et al., 2006; Rowlands et al., 2008). Importantly, two gels of differing acrylamide/bis-acrylamide concentration but similar mechanical properties can bind similar amounts of matrix protein. To optimize the hydrogel coating protocol to the end user's specific proteins and conditions, such a check is necessary. Verification schemes used by Pelham and Wang (1997), as well as other groups, to confirm that relatively uniform protein attachment occurred, are also detailed here.

Finally, there are several choices of ECM proteins for PA hydrogel conjugation. Common ECM proteins include collagen I, collagen IV, laminin, and fibronectin. While these proteins can effectively promote cell attachment, the choice of the ECM protein is important as both integrin signaling and substrate elasticity are cues that affect cell

Extracellular Matrix

10.16.9

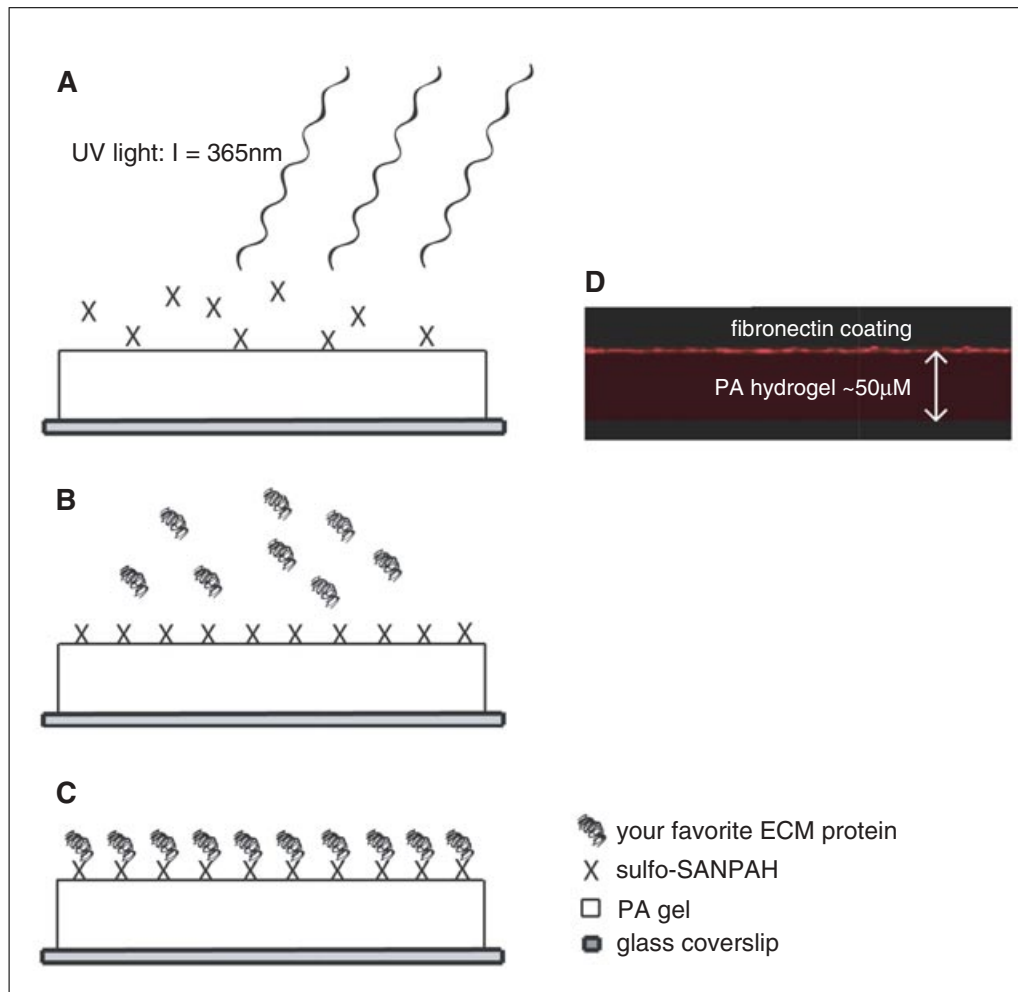

Figure 10.16.4 Schematic of the functionalization procedure for PA hydrogels. **(A)** The surface becomes activated upon addition of sulfo-SANPAH to the PA hydrogel, a reaction catalyzed with 365-nm UV light. **(B)** Overnight attachment of your favorite ECM protein in a 50 mM HEPES solution, pH 8.5. **(C)** Completed functionalization of your favorite ECM protein to the PA hydrogel. **(D)** Confocal cross-sectional fluorescence image of a 34-kPa PA hydrogel functionalized with rat fibronectin, demonstrating that the ECM protein represents a relatively uniform, thin layer of the PA hydrogel. For the color version of this figure go to <http://www.currentprotocols.com/protocol/cb1016>.

behavior (Rehfeldt et al., 2007). For example, while culturing mesenchymal stem cells (MSCs) on relatively stiff substrates promotes osteogenic differentiation of mesenchymal stem cells when collagen I (Engler et al., 2006) or fibronectin is bound (Rowlands et al., 2008), the use of collagen IV and laminin, proteins found in low concentrations in bone, on these same substrates does not result in any osteogenic marker expression (Rowlands et al., 2008). Nevertheless, because collagen I is the most abundant type of collagen found in the body, it is often used as a default surface coating for a variety of cell types (Badylak, 2005). The optimal choice of ECM protein or combinations of proteins thus depends on what will best mimic the *in vivo* microenvironment of the specific cell type.

Materials

PA hydrogels (Basic Protocol 1 or Alternate Protocol)
 0.2 mg/ml sulfosuccinimidyl-6-(4'-azido-2'-nitrophenylamino)-hexanoate
 (sulfo-SANPAH; Pierce Biotechnology)

50 mM HEPES buffer, pH 8.5, filter sterilized
ECM protein(s) of choice
Distilled H₂O or phosphate-buffered saline (PBS; Cellgro, cat. no. 46-013-CM),
sterile
320-nm or 365-nm UV light source
37°C tissue culture incubator

1. Remove dH₂O or PBS from the petri dish with coverslip-gel composite.
2. Add ~500 µl of sulfo-SANPAH solution to the gel surface or enough to cover the entire gel.

Complete coverage is necessary to ensure even protein coating.

Sulfo-SANPAH is light-sensitive and should be shielded from light until use.

3. Place the gel in the 365-nm UV light source at a distance of ~3 in. and expose for 10 min.

Repeat as necessary should insufficient protein bind, or if the coating does not appear uniform using the methods detailed below.

See Figure 10.16.4A for schematic of the attachment of sulfo-SANPAH to the PA hydrogel, catalyzed by 365-nm UV light.

4. Rinse with 2 ml 50 mM HEPES at least two to three times to eliminate excess sulfo-SANPAH.

The HEPES solution should be filter sterilized to ensure that the hydrogels remain as sterile as possible.

5. Add an appropriate amount of ECM protein to 50 mM HEPES, and incubate this solution with the gel overnight at 37°C.

Due to the aqueous instability of the sulfosuccinimidyl ester, conjugation should start immediately upon activation.

Ensure that the protein used in the conjugation has a primary amine group in it. Most extracellular matrix proteins contain such a reactive group. The end user should optimize the density of ligand coating for the specific cell type used.

If making larger gels, placing the gel on a rocker plate can ensure that the solution remains well mixed and evenly coats the gel.

For our setup, we employ concentrations of 0.10 mg/ml for collagen and 10 µg/ml of fibronectin or laminin, which have previously been shown to promote optimal cell behavior in smooth muscle cells (Engler et al., 2004a), fibroblasts (Rajagopalan et al., 2004), and epithelial cells (Williams et al., 2008), respectively. Increasing the collagen concentration within the solution to enhance binding may cause the collagen to precipitate or form a gel once heated to a physiological temperature. When the hydrogels are used for cell culture, media proteins will not continue to attach to unlinked sulfo-SANPAH sites because the reaction will only take place when the pH is 8.5, and media pH is usually 7 to 7.4.

It is critically important that, for successful conjugation of the protein to the PA gel, the protein solution not precipitate. Given the relatively high pH of 8.5 for the reaction, collagen will have a tendency to precipitate. To avoid this, we suggest adding HEPES buffer to the concentrated collagen stock solution slowly, with vigorous vortexing.

See Figure 10.16.4B,C for schematic of the overnight attachment of an ECM protein to the sulfo-SANPAH at the surface of the PA hydrogel.

6. Rinse with 2 ml distilled H₂O or PBS, depending on what was used to dilute the acrylamide.

7. To verify binding amounts, we suggest either using fluorescently labeled (Engler et al., 2004c; Rowlands et al., 2008) or radioactively labeled (Rajagopalan et al., 2004) protein to relate the measured signal to the amount of protein from reference standards. Alternatively, antibody-coated bead binding (Lo et al., 2000) or enzyme-linked immunosorbent assays (ELISA) may be used to confirm protein binding.

Using fluorescently bound proteins may be most effective as they will also enable detection of uniform protein coating. Fluorescently labeled proteins can be added at up to a 1:9 ratio to unlabeled protein in step 5 of this protocol. When observing the gel with a confocal microscope, it will be possible to confirm that functionalization was confined to the top surface of the gel and that it does not vary in intensity by more than 10% (see Fig. 10.16.4D, Rowlands et al., 2008, or Winer et al., 2009).

If there is an intensity variation of more than 10%, additional functionalization steps using sulfo-SANPAH should be performed, i.e., repeat steps 1 to 4 of this protocol prior to adding protein in step 5. Alternatively, increasing sulfo-SANPAH concentration is not advisable, as it will reach its solubility limit.

8. After confirmation of protein binding, or in parallel cultures, add 1 ml of sterile distilled H₂O or PBS to the petri dish or well and place in the tissue culture hood for 30 min under UV for sterilization.
9. Plate cells using standard tissue culture techniques. For isolated cells with only cell-ECM contacts, plate cells at $<10^4$ cells/cm² in their standard medium.

SUPPORT PROTOCOL

CONSTRUCTION OF A GRADIENT-GEL APPARATUS

The construction and setup of the gradient-gel apparatus is presented here. The three main components of the apparatus are the gradient and negative photomasks and the UV light source. Photomask design can simply be made using the gradient tool in Adobe Photoshop and by adjusting the percent gray-scale or using silvered glass etching techniques in a microfabrication facility. Given that the former is a much more accessible technology, we will focus our discussion here to desktop versions for photomask generation. For our particular setup, we use a radial-gradient of 0% to 70% gray-scale, with the center at 0% and the edge at 70% gray-scale. While the gray-scale range can be modulated to any value, 70% was chosen as the maximum gray-scale because a higher value blocked efficient polymerization. The 0% to 70% range allows us to achieve a maximal range of elasticity of the gel associated with a maximal range of gray-scale. Because the edges of the photomask would transmit the least amount of light, the PA hydrogel would be expected to show the least polymerization and thus the lowest modulus of elasticity at the edge of the gels. This radial-gradient design is beneficial because it is easy to find the lowest attainable modulus of elasticity by monitoring the amount of time required for the edge of the hydrogel to just complete polymerization. Our setup uses a small UV light box, which typically emits UV light at 254-nm and 365-nm. It is acceptable to use a UV wavelength outside the optimal Irgacure 2959 absorbance peak of 280 nm with the precaution that longer UV exposure time is needed to deliver the same results. The negative photomask is essentially a black screen that blocks out all excess light by transmitting only an area of light the size of the actual photomask.

While the setup of the gradient-gel apparatus can be altered so that the light box is on top, it is important for the relative order of each component to stay the same. Figure 10.16.2 shows an exploded diagram of our apparatus that illustrates how the UV light should transmit through the chloro-silanated glass slide first before reaching the polymer solution. This order would initiate polymerization at the interface between the polymer solution and the chloro-silanated glass slide allowing the gel surface to receive the most UV light.

Materials

Laser printer
Nitrocellulose film
Photomask design
4 mil transparency film
Negative photomask design
254-nm UV light box
Spacers

1. Create photomask by printing out the desired pattern at 1200 dpi using a laser printer onto nitrocellulose film (see Fig. 10.16.2D as an example).

For our photomask design, the center of the photomask had a gray-scale intensity of 0%, while the edge photomask had a gray-scale intensity of 70%. The photomask design can be created using the gradient tool in Adobe Photoshop.

The photomask should be the same dimensions as the gel itself.

Nitrocellulose film was chosen for the photomask material because it transmits UV light at a wavelength of 254 nm. Typical commercially purchased transparency films do not transmit UV light below ~300 nm due to the presence of benzene rings of the poly(ethylene terephthalate) of the material that absorb at these wavelengths.

2. Print out the negative photomask design at 1200 dpi onto 4 mil transparency film using a laser printer (see Fig. 10.16.2B).

The negative photomask design should be a black print that would transmit UV light in the shape of the photomask.

3. Place the negative photomask on top of the 254-nm UV light box (see Fig. 10.16.2A and B), separated by spacers (see Fig. 10.16.2B).
4. Place the nitrocellulose paper with printed photomask on top of the negative photomask (see Fig. 10.16.2D).
5. Because nitrocellulose paper is sticky, use spacers to avoid contact between the negative photomask and the chloro-silanated glass slide (see Fig. 10.16.2E).
6. Align the negative photomask so that the area of light that is transmitted is directly below the photomask.
7. Proceed to the Alternate Protocol to continue the preparation of radial-gradient hydrogels.

COMMENTARY

Background Information

PA gels were originally used for the separation of proteins in gel electrophoresis as PA is both nearly inert and has tunable cross-linking density. For the same reasons, PA gels can be useful for cell culture techniques, as varying these concentrations results in a quantifiable stiffness known as the modulus of elasticity that cells can sense and respond to. The application of polyacrylamide gels to cell culture was first developed in 1997 to study the responses of 3T3 fibroblasts and rat kidney epithelial cells to mechanical properties of the substrate (Pelham and Wang, 1997).

While this protocol uses PA as the polymer of choice, other materials, such as polydimethylsiloxane, (PDMS), polyethylene glycol (PEG), and hyaluronic acid (HA) are some of the other synthetic and natural substrates with a tunable elasticity that may be used for cell culture (Rehfeldt et al., 2007). The application of this protocol allows one to study how matrix elasticity can affect cell locomotion, focal adhesion structure, cytoskeleton, differentiation, and other potential mechanosensitive cellular processes. Recently, the interest in the effects of matrix elasticity has prompted other researchers to develop

methods to fabricate hydrogels with mechanical properties that oscillate or change with time, temperature, and/or pH (Kaehr and Shear, 2008).

Critical Parameters and Troubleshooting

PA gradient-gel

The greatest challenge to fabricating a PA matrix with a gradient of elasticity is finding the correct set of parameters that can reliably reproduce the gradient. There are many parameters that can affect the modulus of elasticity of the gradient gel. The parameters include the UV bulb intensity, UV light wavelength, distance from the UV light box, Irgacure 2959 concentration, gel thickness, photomask grayscale range, acrylamide and bis-acrylamide concentration, and UV exposure time. Because even minute changes in the setup can affect the final values of the gradient gel, it is necessary for the researcher to optimize these parameters to create the desired results. It is recommended to vary the UV exposure time and the acrylamide and bis-acrylamide concentrations, keeping all other parameters constant. To increase the range of the modulus of elasticity, increase the relative acrylamide and bis-acrylamide concentrations. To increase the modulus of elasticity of the hydrogels, increase the UV exposure time. There are several references to measure the modulus of elasticity of the gels by AFM (Domke and Radmacher, 1998; Rotsch et al., 1999; [Rotsch and Radmacher, 2000](#)).

Gel attachment

When separating the chloro-silanated glass slide from the gel, the gel may not be completely attached to the amino-silanated coverslip, resulting in uneven gel attachment. This is especially common when creating the gradient-gels, in which the polymerization starts on the side of the gel facing the chloro-silanated glass slide. To ensure uniform gel attachment, make sure that the glass slide is freshly coated with DCDMS and that the amino-silanated coverslips are used as quickly as possible after preparation.

Gel thickness

Another obstacle in the fabrication of the hydrogels is uneven gel thickness. Uneven gel thickness usually results from completing the protocol on a tilted surface, causing the polymer solution to aggregate to one side. To ensure uniform gel thickness, make sure

that a flat surface is chosen to complete the protocol.

Anticipated Results

Support Protocol. A basic gradient-gel apparatus that can be assembled in a few minutes and used repeatedly for the fabrication of gradient-gels.

Basic Protocol 1. The researcher should observe that the amino-silanated glass coverslips are hydrophilic while the chloro-silanated glass slides are hydrophobic. After gel attachment, a translucent PA gel of $\sim 50 \mu\text{l}$ should be uniformly attached to the amino-silanated glass coverslip. The modulus of elasticity of the statically compliant hydrogels should match the values found in Table 10.16.1 and can be confirmed by using AFM analysis.

Basic Protocol 2. After overnight incubation with the ECM protein, the surface of the hydrogel should have covalent linkages to the protein. The researcher can confirm protein attachment by using immunofluorescent staining such as that employed by Rowlands and coworkers (Rowlands et al., 2008) or with bead assays as with Lo and coworkers (Lo et al., 2000). If one uses the conditions described in this unit, the surface concentration of the ligand should be ~ 340 to 450 molecules per μm^2 (Gaudet et al., 2003).

Time Considerations

Support Protocol. The gradient-gel apparatus can be completed within 1 hr.

Basic Protocol 1. It takes ~ 15 min to prepare NaOH-coated glass coverslips, which can be stored indefinitely. The rest of the preparation of the chloro-silanated glass slides and amino-silanated glass coverslips takes ~ 50 min. The steps that complete the attachment of the statically compliant PA hydrogel takes ~ 40 min. For the radial-gradient hydrogel, it generally takes ~ 15 min for the Irgacure 2959 with acrylamide and bis-acrylamide to completely dissolve and ~ 60 min to degas. Each gel then takes a few minutes to polymerize, depending on the acrylamide and bis-acrylamide concentration and the desired gradient.

Basic Protocol 2. The set up and UV exposure to cross-link the sulfo-SANPAH to the PA hydrogel takes ~ 20 min. The attachment of the ECM protein to the PA hydrogel can be completed overnight. Finally, before plating cells, the PA hydrogels should be sterilized for 30 min by placing them in the tissue culture hood under UV.

Literature Cited

- Badylak, S.F. 2005. Regenerative medicine and developmental biology: the role of the extracellular matrix. *Anat. Rec. B New Anat.* 287:36-41.
- Cukierman, E., Pankov, R., Stevens, D.R., and Yamada, K.M. 2001. Taking cell-matrix adhesions to the third dimension. *Science* 294:1708-1712.
- Discher, D.E., Janmey, P., and Wang, Y.L. 2005. Tissue cells feel and respond to the stiffness of their substrate. *Science* 310:1139-1143.
- Discher, D.E., Mooney, D.J., and Zandstra, P.W. 2009. Growth factors, matrices, and forces combine and control stem cells. *Science* 324:1673-1677.
- Domke, J. and Radmacher, M. 1998. Measuring the elastic properties of thin polymer films with the atomic force microscope. *Langmuir* 14:3320-3325.
- Engler, A., Bacakova, L., Newman, C., Hategan, A., Griffin, M., and Discher, D. 2004a. Substrate compliance versus ligand density in cell on gel responses. *Biophys. J.* 86:388a-388a.
- Engler, A.J., Griffin, M.A., Sen, S., Bonnemann, C.G., Sweeney, H.L., and Discher, D.E. 2004b. Myotubes differentiate optimally on substrates with tissue-like stiffness: Pathological implications for soft or stiff microenvironments. *J. Cell Biol.* 166:877-887.
- Engler, A.J., Richert, L., Wong, J.Y., Picart, C., and Discher, D.E. 2004c. Surface probe measurements of the elasticity of sectioned tissue, thin gels and polyelectrolyte multilayer films: Correlations between substrate stiffness and cell adhesion. *Surf. Sci.* 570:142-154.
- Engler, A.J., Sen, S., Sweeney, H.L., and Discher, D.E. 2006. Matrix elasticity directs stem cell lineage specification. *Cell* 126:677-689.
- Fairbanks, B.D., Schwartz, M.P., Bowman, C.N., and Anseth, K.S. 2009. Photoinitiated polymerization of PEG-diacrylate with lithium phenyl-2,4,6-trimethylbenzoylphosphinate: Polymerization rate and cytocompatibility. *Biomaterials* 30:6702-6707.
- Fedorovich, N.E., Oudshoorn, M. H., van Geemen, D., Hennink, W. E., Alblas, J., and Dhert, W.J.A. 2009. The effect of photopolymerization on stem cells embedded in hydrogels. *Biomaterials* 30:344-353.
- Flanagan, L.A., Ju, Y.E., Marg, B., Osterfield, M., and Janmey, P.A. 2002. Neurite branching on deformable substrates. *Neuroreport* 13:2411-2415.
- Fung, Y.C. 1993. *Biomechanics: Mechanical Properties of Living Tissues*, 2nd ed. Springer-Verlag, New York.
- Gaudet, C., Marganski, W.A., Kim, S., Brown, C.T., Gunderia, V., Dembo, M., and Wong, J.Y. 2003. Influence of type I collagen surface density on fibroblast spreading, motility, and contractility. *Biophys. J.* 85:3329-3335.
- Georges, P.C. and Janmey, P.A. 2005. Cell type-specific response to growth on soft materials. *J. Appl. Physiol.* 98:1547-1553.
- Grabarek, Z. and Gergely, J. 1990. Zero-length crosslinking procedure with the use of active esters. *Anal. Biochem.* 185:131-135.
- Kaehr, B. and Shear, J.B. 2008. Multiphoton fabrication of chemically responsive protein hydrogels for microactuation. *Proc. Natl. Acad. Sci. U.S.A.* 105:8850-8854.
- Khatiwala, C.B., Peyton, S.R., and Putnam, A.J. 2006. Intrinsic mechanical properties of the extracellular matrix affect the behavior of pre-osteoblastic MC3T3-E1 cells. *Am. J. Physiol. Cell Physiol.* 290:C1640-C1650.
- Lo, C.M., Wang, H.B., Dembo, M., and Wang, Y.L. 2000. Cell movement is guided by the rigidity of the substrate. *Biophys. J.* 79:144-152.
- Pelham, R.J. Jr. and Wang, Y. 1997. Cell locomotion and focal adhesions are regulated by substrate flexibility. *Proc. Natl. Acad. Sci. U.S.A.* 94:13661-13665.
- Rajagopalan, P., Marganski, W.A., Brown, X.Q., and Wong, J.Y. 2004. Direct comparison of the spread area, contractility, and migration of balb/c 3T3 fibroblasts adhered to fibronectin- and RGD-modified substrata. *Biophys. J.* 87:2818-2827.
- Rehfeldt, F., Engler, A.J., Eckhardt, A., Ahmed, F., and Discher, D.E. 2007. Cell responses to the mechanochemical microenvironment—implications for regenerative medicine and drug delivery. *Adv. Drug Deliv. Rev.* 59:1329-1339.
- Reinhart-King, C.A., Dembo, M., and Hammer, D.A. 2005. The dynamics and mechanics of endothelial cell spreading. *Biophys. J.* 89:676-689.
- Reinhart-King, C.A., Dembo, M., and Hammer, D.A. 2008. Cell-cell mechanical communication through compliant substrates. *Biophys. J.* 95:6044-6051.
- Rotsch, C. and Radmacher, M. 2000. Drug-induced changes of cytoskeletal structure and mechanics in fibroblasts: An atomic force microscopy study. *Biophys. J.* 78:520-535.
- Rotsch, C., Jacobson, K., and Radmacher, M. 1999. Dimensional and mechanical dynamics of active and stable edges in motile fibroblasts investigated by using atomic force microscopy. *Proc. Natl. Acad. Sci. U.S.A.* 96:921-926.
- Rowlands, A.S., George, P.A., and Cooper-White, J.J. 2008. Directing osteogenic and myogenic differentiation of MSCs: Interplay of stiffness and adhesive ligand presentation. *Am. J. Physiol. Cell Physiol.* 295:C1037-C1044.
- Wang, H.B., Dembo, M., and Wang, Y.L. 2000. Substrate flexibility regulates growth and apoptosis of normal but not transformed cells. *Am. J. Physiol. Cell Physiol.* 279:C1345-C1350.
- Williams, C.M., Engler, A.J., Slone, R.D., Galante, L.L., and Schwarzbauer, J.E. 2008. Fibronectin expression modulates mammary epithelial cell

proliferation during acinar differentiation. *Cancer Res.* 68:3185-3192.

Winer, J.P., Janmey, P.A., McCormick, M.E., and Funaki, M. 2009. Bone marrow-derived human mesenchymal stem cells become quiescent on soft substrates but remain responsive to chemical or mechanical stimuli. *Tissue Eng. Pt A* 15:147-154.

Wong, J.Y., Velasco, A., Rajagopalan, P., and Pham, Q. 2003. Directed movement of vascular smooth muscle cells on gradient-compliant hydrogels. *Langmuir* 19:1908-1913.